

**Type 420**  
**Series 400 (Streamline)**

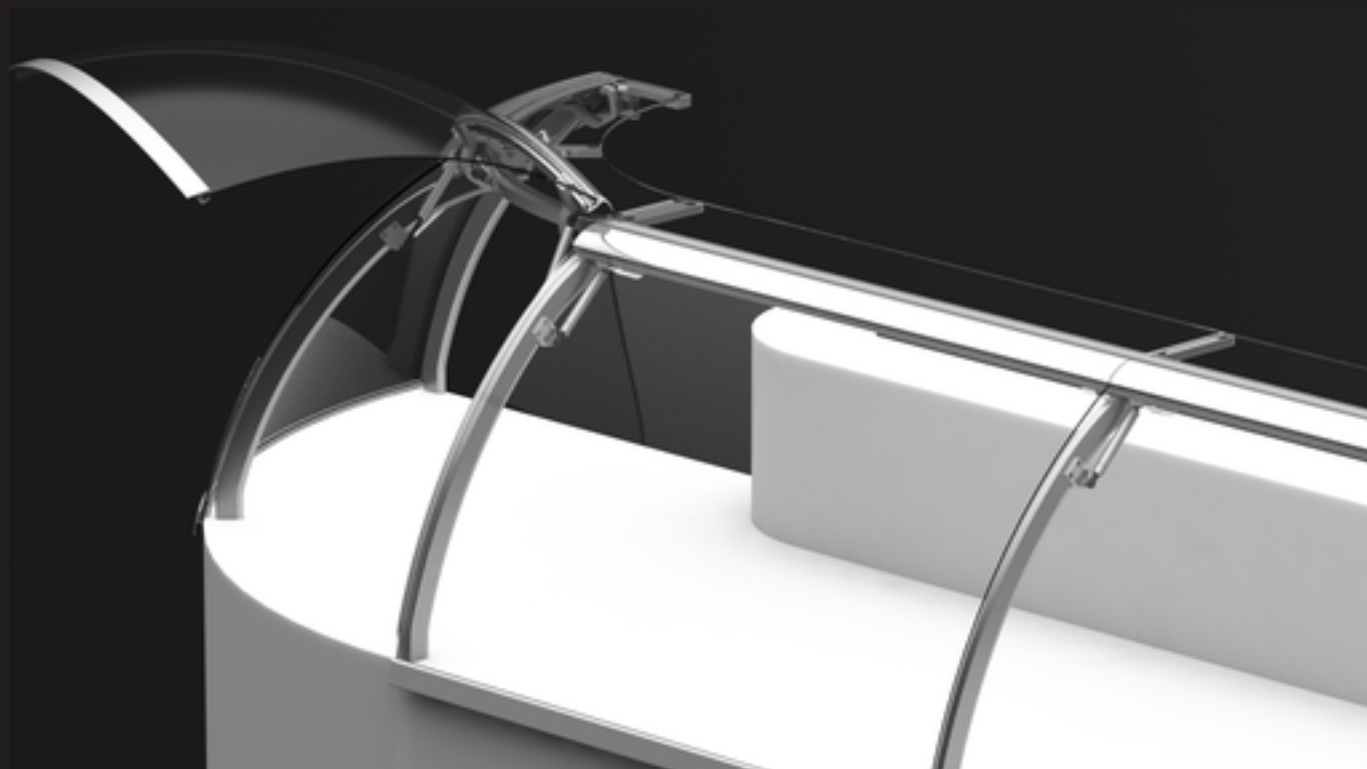

## Product characteristics

- high stability - for spherical front glasses
- glass 46.64°/668 mm
- internal and external corners possible
- glasses damped on closing
- large opening angle 165° (maximum access for cleaning and reloading with merchandise)
- maximum glass length L = 960 mm
- aluminum physiologically harmless
- surface silver satin anodized (color 011) or black anodized (color 016) - other colors on request

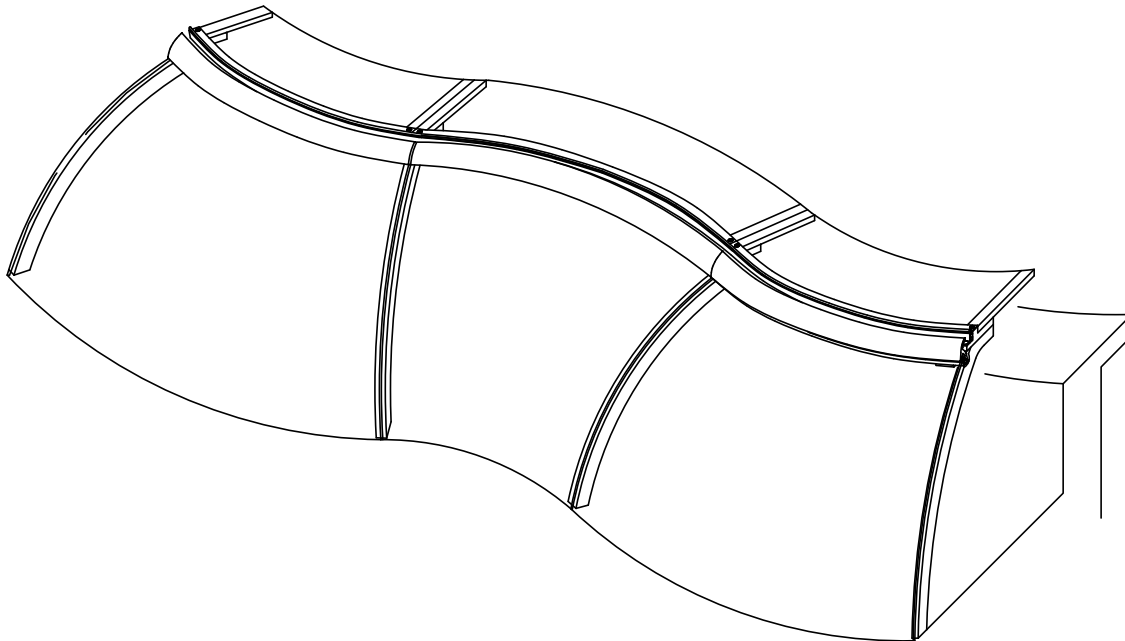

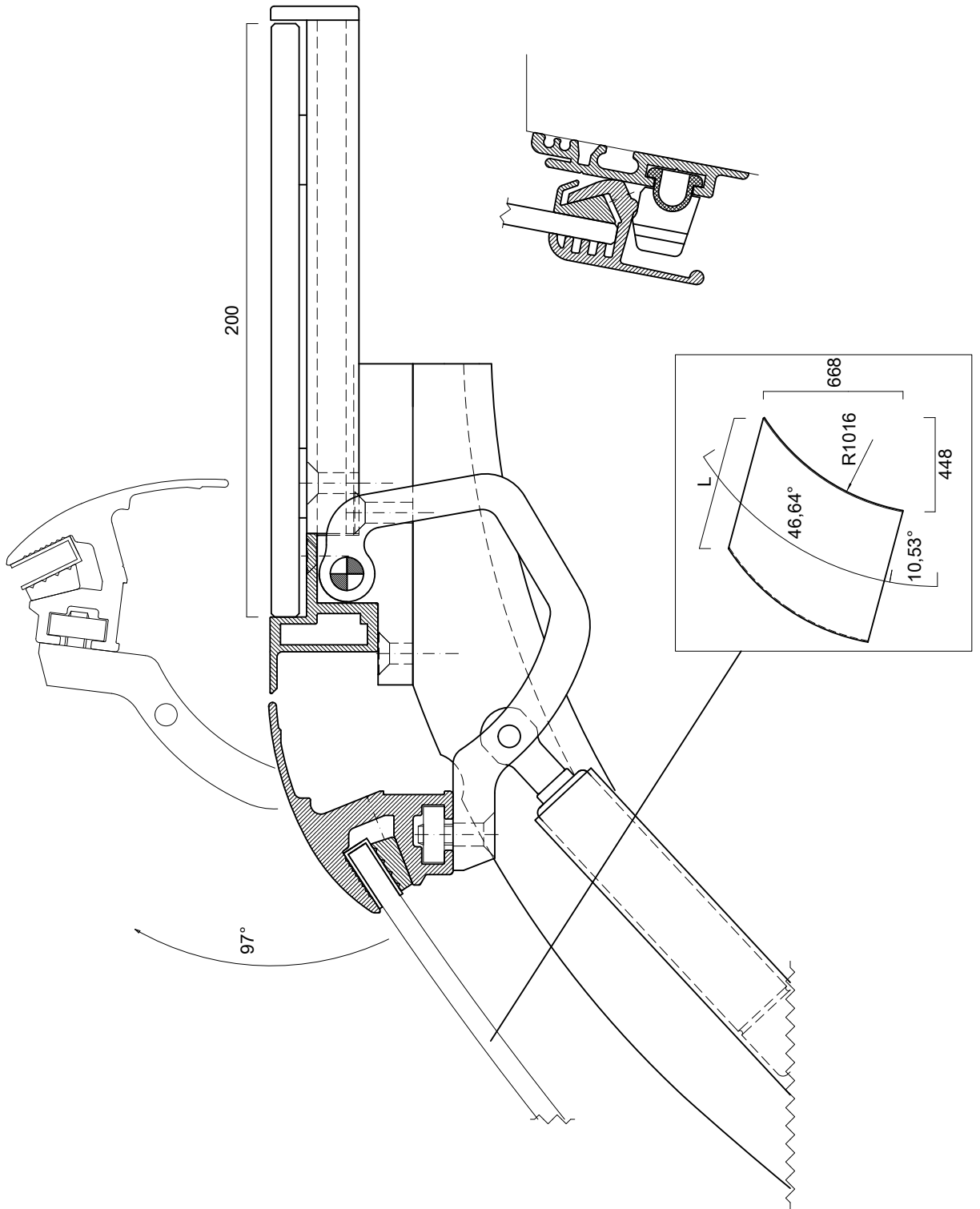

## Planning information

- front glass 6 mm ESG
- height max. 700 mm
- top service plate 8 mm tempered
- depth max. 500 mm
- opening angle 97°

glass dimensions (no warranty for glasses)

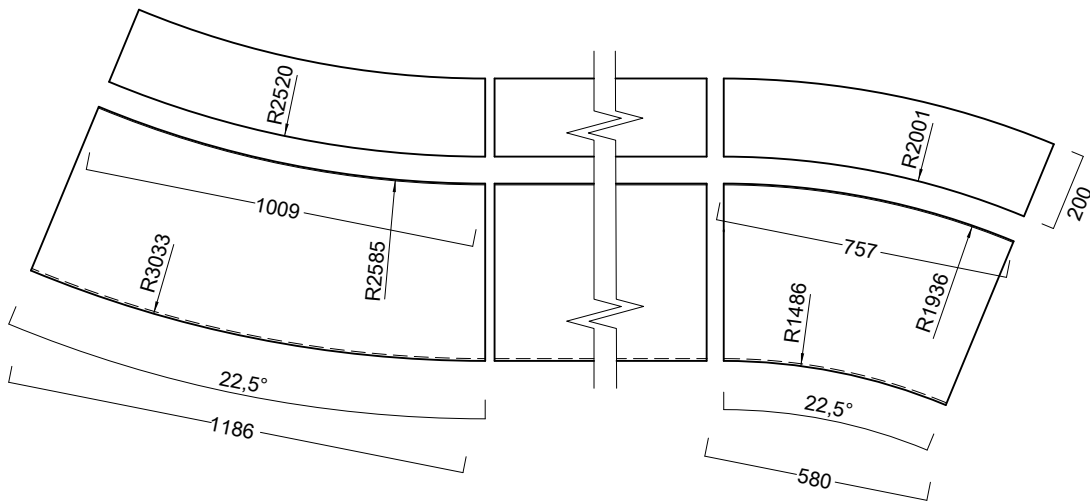

22.5°

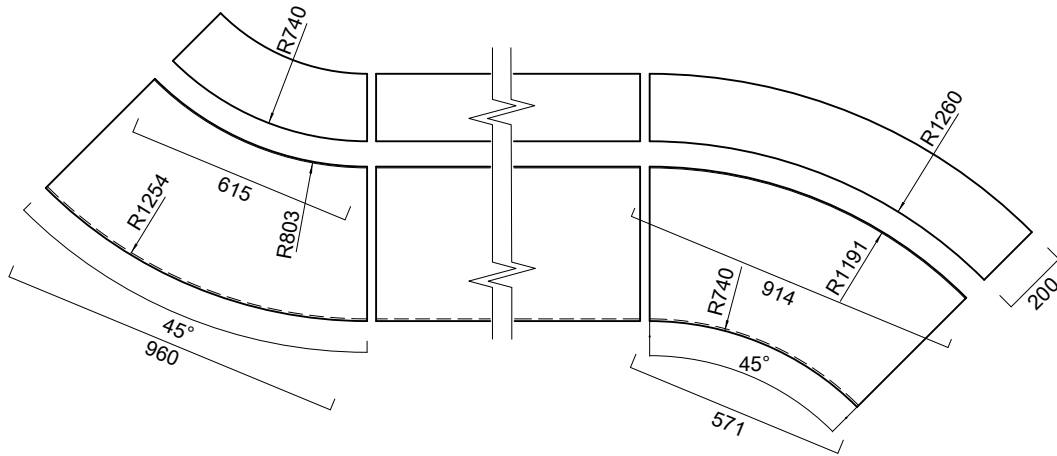

45°

**gas ram pressures for 46.64°  
calculation of gas ram pressures without hand grip**

- 943 mm 500 N
- 1243 mm 600 N
- 1443 mm 700 N

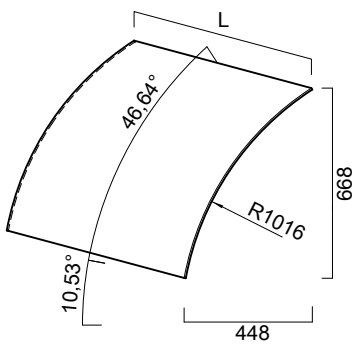

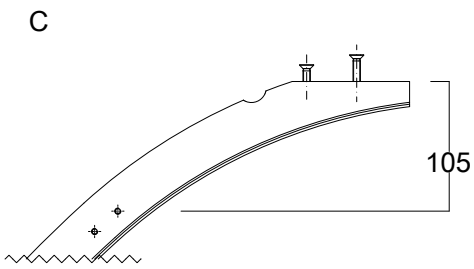
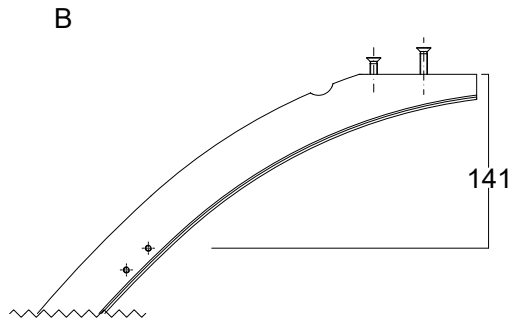
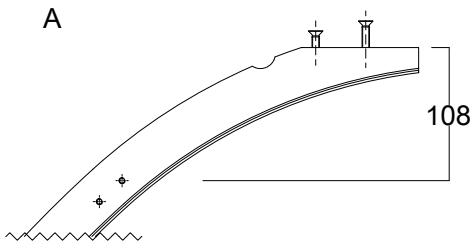

**A= strut end / center for straight case**  
**B= strut left / right for internal corner**  
**C= strut left / right for external corner**

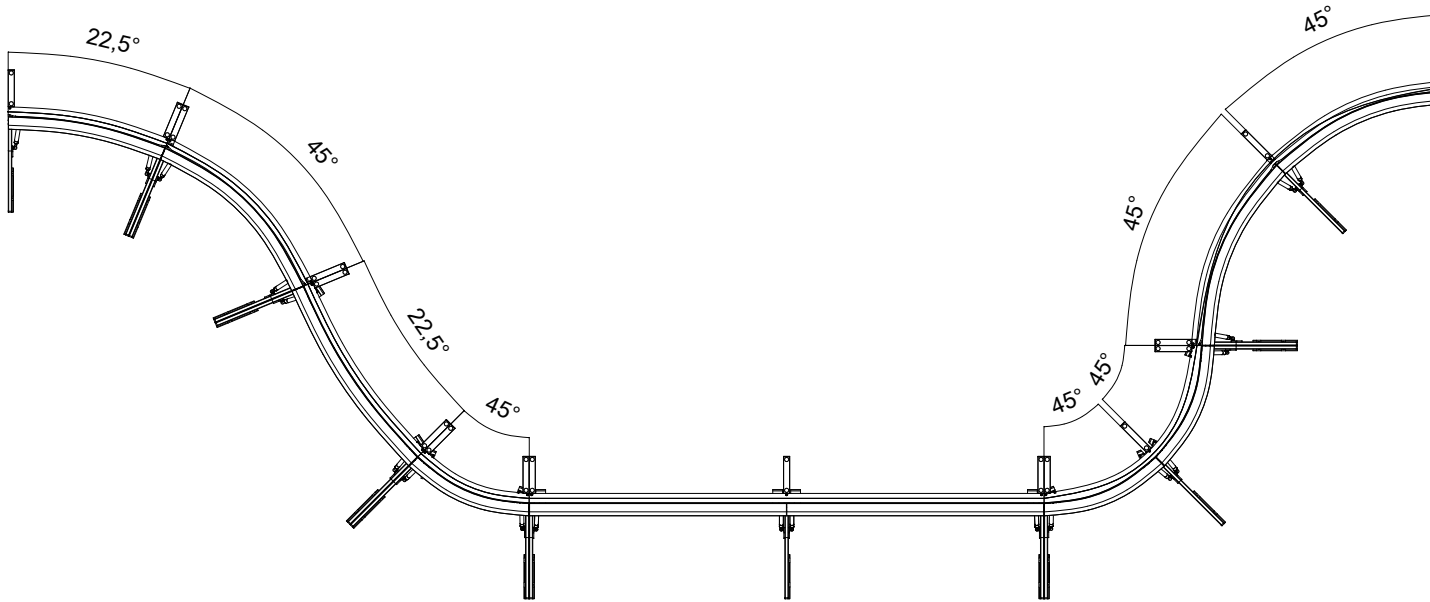

possible positioning  
straight case 943 mm / 1243 mm / 1443 mm  
external corner 45° internal corner 45°  
external corner 22,5° internal corner 22,5°

**Type 420**  
Picture

**Product**

**Part number**

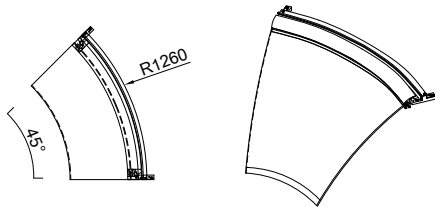

**Support set complete**  
internal corner 45°  
incl. front profile,  
glass clamp profile and  
hand grip profile bent,  
gas rams 300 N

**14.446.5791.XXX**

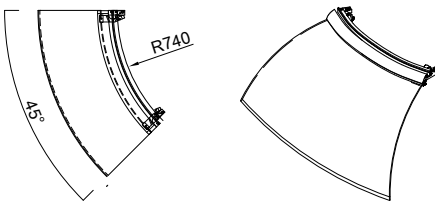

**Support set complete**  
external corner 45°  
incl. front profile  
glass clamp profile and  
hand grip profile bent,  
gas rams 400 N

**14.446.5796.XXX**

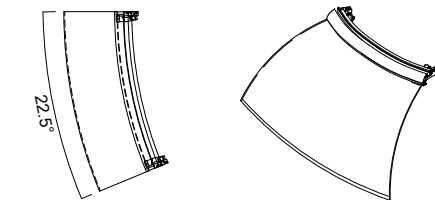

**Support set complete**  
external corner 22,5°  
incl. front profile,  
glass clamp profile and  
hand grip profile bent,  
gas rams 400 N

**14.446.5926.XXX**

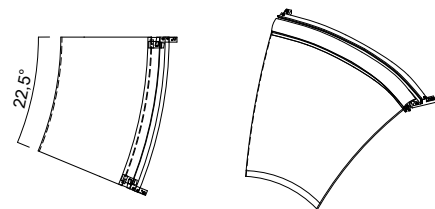

**Support set complete**  
internal corner 22,5°  
incl. front profile  
glass clamp profile and  
hand grip profile bent,  
gas rams 300 N

**14.446.5761.XXX**

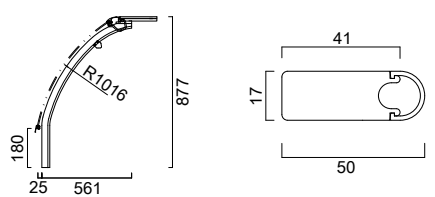

**Strut for straight case**  
without gas ram

end  
center

**14.446.5011.XXX**

**14.446.5012.XXX**

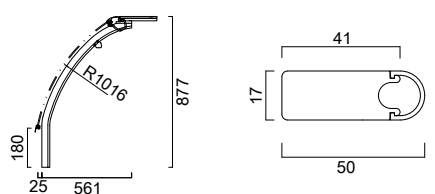

**Strut for internal corner**  
without gas ram  
(see above)

left / right

**14.446.5013.XXX**

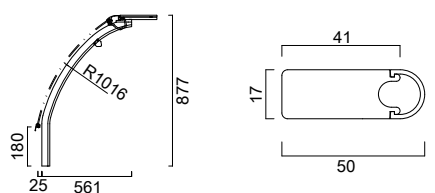

**Strut for external corner**  
without gas ram  
(see above)

left / right

**14.446.5014.XXX**

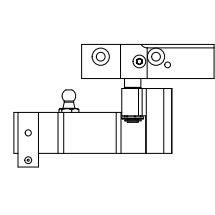
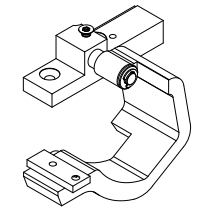
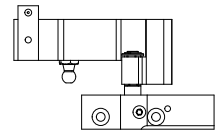
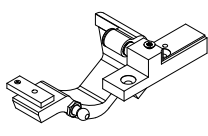
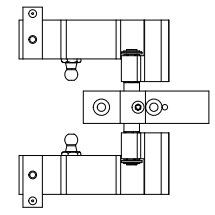
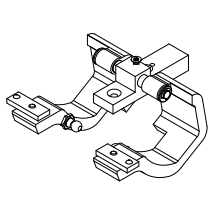
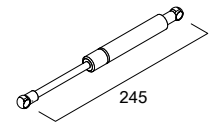
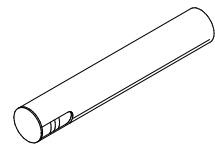
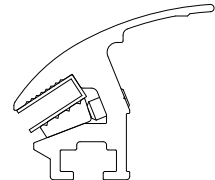
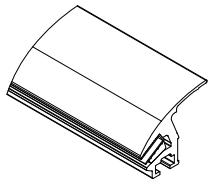

Picture	Product		Part number
	Lift-up element, for straight case	left	14.446.5711.XXX
			
	Lift-up element, for straight case	right	14.446.5712.XXX
			
	Lift-up element, for straight case	center	14.446.5713.XXX
			
	Gas ram Lift-O-Mat	100N 200N 250N 300N 400N 500N 600N 700N 800N 900N 1,000N 1,100N 1,200N	14.044.3218.051 14.044.3294.051 14.044.3295.051 14.044.3267.051 14.044.3268.051 14.044.3269.051 14.044.3270.051 14.044.3271.051 14.044.3296.051 14.044.3689.051 14.044.3690.051 14.044.3691.051 14.044.3692.051
	Cover for gas ram for straight case 14.446.6008.XXX	external corner internal corner	14.446.6008.XXX 14.446.6009.XXX
	Glass clamp profile, complete	5000mm	14.446.5510.XXX
			

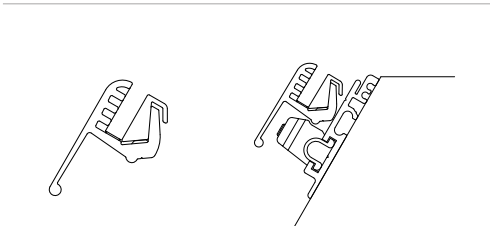
Picture	Product	Part number
	<b>Front profile</b> 5000mm	<b>14.052.3384.XXX</b>
	<b>Connector</b>	<b>14.446.6001.XXX</b>
	<b>Support</b> for internal corner and for straight case	200mm <b>14.446.5704.XXX</b>
	<b>Support</b> for external corner	left <b>14.446.5705.XXX</b> right <b>14.446.5706.XXX</b>
	<b>Hand grip profile</b> complete	5000mm <b>19.441.6306.XXX</b>
	<b>Striker profile</b>	5000mm <b>19.052.3776.XXX</b>
	<b>Groove profile</b> plastic, transparent	25m <b>19.054.0500.087</b>

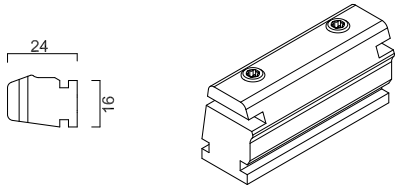
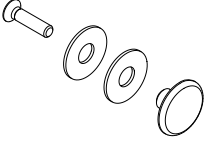
Picture	Product	Part number
	<b>Keeper for striker profile</b> plastic	<b>19.441.6543.094</b>
	<b>Side-glass fixing</b>	<b>14.448.5000.XXX</b>

